

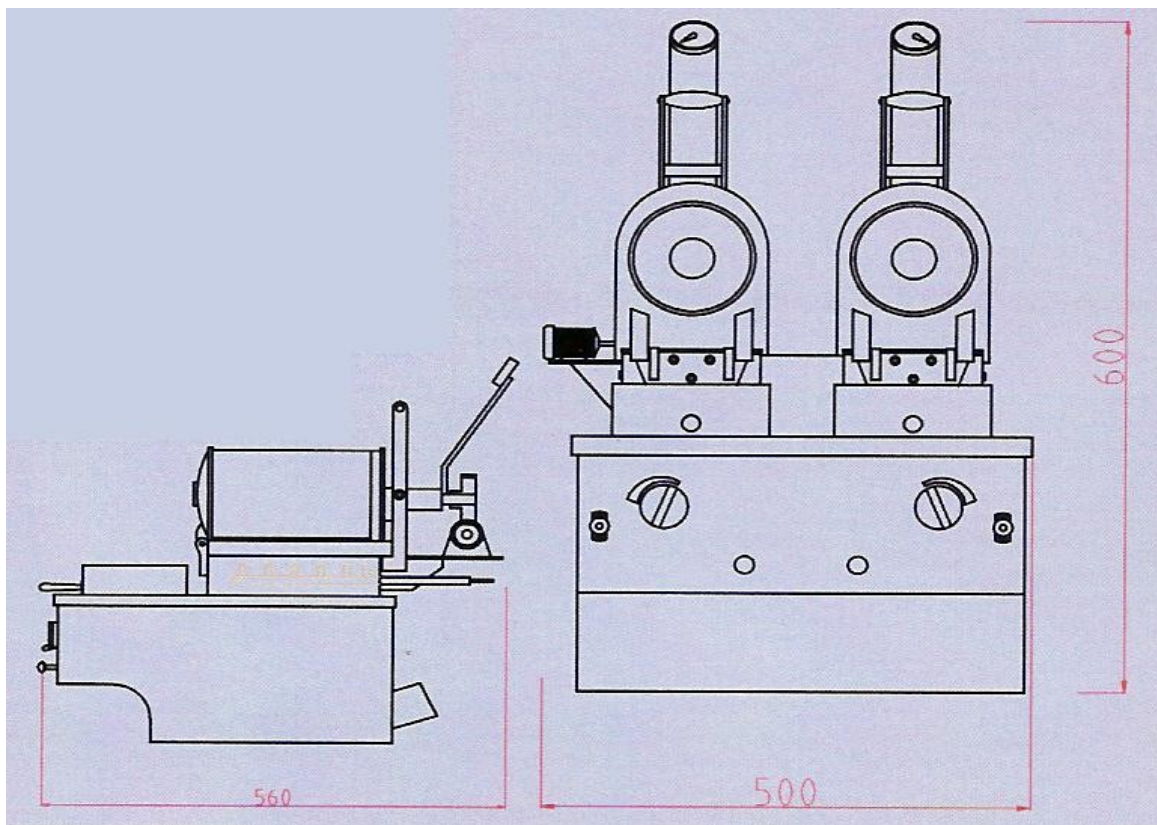

Technical Specifications	Un.	CRG100-1	CRG100-2
Batch capacity	kg/Lbs	100/3,40	100/3,40-200/6,80
Control design		Manuel	Manuel
Roasting time	Min	15-20	15-20
Safety device		Yes	Yes
Operation type burner		Modelation	Modelation
Fuel type (Gas oven)		Propane or Natural Gas	Propane or Natural Gas
Electrical oven		Resistor	Resistor
Power Requirements (Gas oven)	Amp	3	5
Voltage/frequency/phases	V/Hz/Ph	220/50/1	220/50/1
∅ Exhaust chimney (roaster cyclone)	mm/inch	100/4	100/4
Roaster weight with cooler and cyclone	kg/Lbs	25/55	48/105
Roaster fan motor	Hp	0,5	0,5
Drum gear box	Hp	25	25



Bussink
Machinery
International

Bussink Machinery International

ˆt Goor 35
7071 PC Ulfst – The Netherlands
Tel. 0031 315 241655 Fax 0031 315 642653
www.bmi-coffeeproducts.com
info@bmi-coffeeproducts.com